



## LEXINGTON POLICE DEPARTMENT

111 Maiden Lane, P.O. Box 397  
Lexington, SC 29072  
(803) 359-6260



Sworn Officer Employment Information  
Please Read Prior to Beginning Your Application

**DO NOT** in any way bind, staple or paperclip **ANY** portion of your application packet. **DO NOT** print the application front to back.

### Application Supplemental Requirements:

- Copy of 10 year certified driver's history from all states currently or previously licensed.
- Copy of current (within last 6 months) credit report with no missing pages
- Copy of college transcripts, if applicable
- Copy of social security card
- Copy of birth certificate
- Copy of high school diploma (or GED) and college diploma, if applicable
- Copy of DD-214, if applicable
- Copy of your SC Class 1 Law Enforcement Certification if you are currently certified
- Application completed in its ENTIRETY. All items that are not applicable should be marked N/A.

### Duration of Process:

- All applications are kept on file until such time as we begin reviewing and processing them.
- This occurs on an as needed basis dependant upon personnel needs within the department.
- Once this occurs the process takes approximately 6-8 weeks.
- You will be notified during this process on the status of your application and of any tests/interviews.

### Reapplication Process:

- Should you not be selected for any current position, you must re-submit the entire application package to be considered for any future positions. You may not reapply for one year from your initial application submission.

### General Requirements for Job Applicants:

- 21 years of age
- High school diploma or equivalent
- Minimum of Associates Degree (accredited institution) OR certified law enforcement officer OR foreign language fluency (tested) OR honorable military service OR two years public safety experience.
- Ability to complete the South Carolina Criminal Justice Academy
- Possession of valid South Carolina driver's license at time of any employment offer
- Vision correctable to 20/20

## General Selection Process Requirements

(Also see Appendix B "Selection Process for further information)

Successful completion of:

- Application Pre-Screening
- Pre-Employment Physical Fitness Testing (As described in Appendix A)
- Appearance before interview board
- Thorough background investigation
- Psychological screening
- Oral interview(s) with Chief of Police and Town Administrator
- Physical exam and drug screen

## Ineligibility Factors:

- Criminal History. Conviction (or plead guilty/no contest) of any of the following crimes:
  - Criminal domestic violence, including assault against a domestic partner, spouse, child or parent;
  - Crime of moral turpitude (crimes that involve fraud, dishonest behavior, breach of duty to society, etc.);
  - Crimes of any type which carries a six months jail sentence or more or the South Carolina State law equivalent within the last five years;
  - Adult commission of undetected crimes of a serious or repetitive nature; or
  - Any Felony.
- Traffic Violations.
  - More than four negative points on a South Carolina Operators License or the equivalent for out of state licenses. Points may be negated prior to application by attending defensive driving school offered by the Division of Motor Vehicles;
  - More than five moving violations on your ten year driving record;
  - Any conviction of eluding police, racing, leaving the scene of an accident, or driving under the influence of drugs or alcohol; or
  - Refusal to take a blood or breath test.
- Credit
  - Demonstrated history of financial irresponsibility (examples include unpaid collections or unsatisfactory judgments where no payment plan has been established. Bankruptcies will be evaluated based on the time frame, circumstances, other measures pursued and restoration of credit).
  - Being in default on a student loan guaranteed through the federal government.
- Drugs
  - Any involvement in the sale or distribution of illegal drugs as an adult;
  - Juvenile involvement in the sale or distribution of illegal drugs is an area of concern which will be given careful scrutiny in the context of the full investigation/review;
  - Any illegal possession of heroin, cocaine, hallucinogens or any other schedule 1 or 2 drug, or any derivative thereof, as defined in the Code of South Carolina within the last ten years;
  - Illegal possession of anabolic steroids within the last three years; or
  - Illegal possession of marijuana or a derivative thereof within the last 36 months.
- Others
  - Dishonorable discharge from military service;
  - Untruthfulness and/or intentional withholding of information on any application, interview, or paperwork associated with the position. Examples of intentional withholding of information would include deliberate inaccuracies or incomplete statements; or
  - Cheating on any examination or testing associated with the position.

- Note
  - This is not intended to be an exhaustive listing of background disqualifiers. Applicants who are successful in the initial phase will undergo a thorough background investigation which may include a polygraph examination. Areas of concern will be evaluated on a case by case basis within the context of the full investigation/review. Examples of areas of concern may include, but are not limited to the following:
  - Reduction of charges as a result of a plea agreement or other form of sentencing disposition prior to a conviction in any of the aforementioned criminal and driving history categories;
  - Crimes committed as a juvenile, including undetected crime;
  - Patterns of reckless and/or irresponsible driving;
  - Conviction(s) of driving under the influence;
  - Illegal drug possession that does not fall within the parameters defined above;
  - Less than honorable military discharge;
  - Erratic work record or unfavorable employment references; and
  - Pending litigation or prosecution for criminal offenses must be resolved prior to consideration for employment.
  - The Lexington Police Department has a zero-tolerance concerning domestic violence.

**Application Hints:**

- Type or print legibly using black ink.
- Provide copies of all required documentation as listed on the Employment Information page. Copies cannot be made for you at the time you submit your application. The Lexington Police Department cannot guarantee that any originals of the required documentation can be returned.
- Grossly incomplete applications are discarded. Minor omissions are still considered however may reflect poorly upon the applicant as well as delay your application process.
- Review your application thoroughly and make sure all information is supplied, directions are followed, and required documents submitted. Your application and the ability to follow directions in completing it is our first impression of you.
- You are strongly encouraged to mark areas that do not apply with “N/A” so as not to leave it to our interpretation as to why a line was blank.
- If there is not enough room supplied for the requested information or you wish to explain further, you may attach additional pages to the application. The additional pages should be properly referenced to the item and item number in the application.
- *Please have notarized the two required places within the application packet. This can be done by our front desk administrative personnel if you deliver your application to us.*
- While we appreciate the submission of a resume, copies of all certifications held, etc., such items are not necessary as all necessary information is thoroughly covered within the application itself. Such items often are discarded.
- Please return your loose (not stapled, bound, clipped, etc.) application in the 8x10 envelope provided. In the rare instance that the documents do not fit within such envelope, please submit your application within a similar, but larger, envelope.
- Pursuant to Federal Legislation, you are entitled to a free annual credit report from all three of the major credit bureaus. These can be obtained by visiting [www.annualcreditreport.com](http://www.annualcreditreport.com) or calling 877-322-8228.
- Otherwise copies of your credit report can be requested from any of the three major credit reporting bureaus individually listed below for a fee.

| <u>Company</u> | <u>Web Address</u>   | <u>Telephone #</u> |
|----------------|--|--------------------|
| Equifax        | <a href="http://www.equifax.com">www.equifax.com</a>       | 1-800-685-1111     |
| Experian       | <a href="http://www.experian.com">www.experian.com</a>     | 1-888-397-3742     |
| Trans-Union    | <a href="http://www.transunion.com">www.transunion.com</a> | 1-800-888-4213     |

**Appendix A**  
**Notification of Pre-Employment Physical Fitness Qualification Testing**

*It is the policy of the Lexington Police Department that candidates for employment demonstrate the ability to carry out daily tasks with vigor and alertness, without undue fatigue, and with the ability to meet physical stresses encountered in emergency situations. To that end, all applicants selected for participation in the Department's selection process are required to undergo pre-employment physical fitness qualification testing. Any applicant who fails to meet the established standard will no longer be considered a viable candidate for employment and will be terminated from the Department's selection process. The following is a brief overview of the Pre-Employment Physical Abilities Test and the standards which must be satisfied for successful fulfillment of this requirement.*

The course measures a total of 870 feet (290 yards/265.2 meters). The course consists of a series of nine interspersed individual tasks, arranged in a continuous format that may be viewed as being essential (physical) job-tasks for law enforcement: running, jumping (low hurdle), climbing stairs, low crawling, jumping (broad-type), climbing a fence (chain-link/four feet), climbing through a window, moving/dragging a weight (150 pounds), and changing direction on the run.

- The applicant starts the course at a point, indicated in green on the course map.
- The applicant runs one and ¾ laps around the perimeter of the course and enters the interior of the course at the point indicated in blue on the course map.
- The first obstacle encountered in the interior consists of two low hurdles, one and a half feet high and four feet long, placed 13 feet apart.
- After clearing the hurdles, stairs (five steps up to a 32-inch wide landing, 45 inches above the floor, and five steps down) must be negotiated twice (note that each step has a 7.5 inch rise and tread that is 11 inches wide).
- Once the stair event is completed another low hurdle must be cleared; the applicant must then successfully negotiate a low crawl under an obstacle set at 2 ½ feet above the floor.
- Make a turn and clear a ditch simulation that is six feet in width.
- After another turn, a chain-link fence (four feet in height) must be climbed.
- Two additional turns made, and a four-foot high window (opening is 3' wide x 4.5' high) must be successfully entered.
- The applicant must then drag a 150-pound dead weight a distance of 20 feet.
- After the weight drag, the applicant exits the course, completes one final lap around the perimeter and finishes at the point indicated in red on the course map.
- The applicant must complete the course in **2 minutes 6 seconds or less**.

Applicants will be notified in writing at least one week prior to their scheduled test date if selected to be tested. The applicant shall be responsible for wearing proper attire suited for participation in the test. An example of proper attire would consist of a solid colored t-shirt, sweatpants/athletic pants/ or military style BDU pants, and athletic shoes. Wearing shorts will not be permitted. It is also recommended that applicants wear applicable supportive undergarments. Gloves and kneepads may be worn at the applicant's discretion but must be supplied by the applicant. The following page contains a diagram of the course. In signing this form, I acknowledge that I have been duly advised of the requirement for pre-employment physical fitness testing and agree to participate in said testing at the convenience of the Lexington Police Department.

\_\_\_\_\_  
Signature of Applicant

\_\_\_\_\_  
Date

**Lexington Police Department**



# Pre-Employment Physical Abilities Test Course

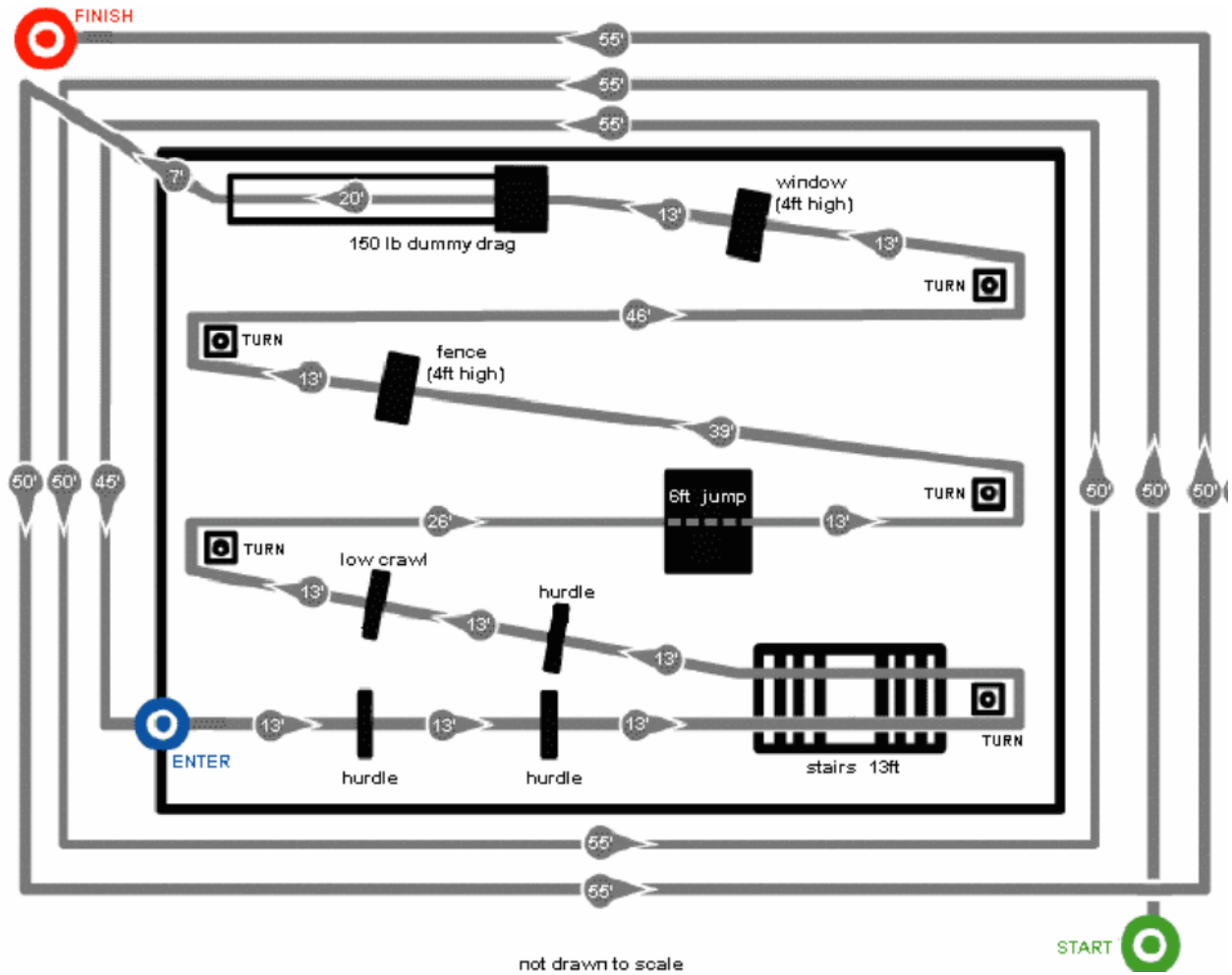

# LEXINGTON POLICE DEPARTMENT

## Appendix B Sworn Officer Selection Process

Applicants Copy  
(Do Not Return)

Once we begin processing applications for open positions, steps 2-9 may take approximately 6-8 weeks.

- STEP 1:**        **Application:**  
The individual submits an application and is contacted via letter to confirm receipt of such.
- STEP 2:**        **Pre-Interview Screening of Applicants:**  
The application is reviewed by Command Staff personnel. Recommendations are made to the Chief of Police who culls unacceptable applications based on bona fide occupational qualifications.
- STEP 3:**        **Pre-Employment Physical Fitness Test**  
Applicants are notified to attend pre-employment physical fitness testing in accordance with established Department requirements. Applicants who fail to meet the established minimum physical fitness requirements are eliminated from the selection process.
- STEP 4:**        **Formal Selection Board:**  
Applicants are notified to attend an initial interview before a board of five personnel. Interview questions are predetermined and approved by the Chief of Police. Recommendations are formulated and forwarded to the Chief of Police.
- STEP 5:**        **Background Investigation and Interview:**  
Upon successful completion of Step 4, a background investigation / interview is conducted by the Department for all remaining applicants. Recommendations are formulated and forwarded to the Chief of Police.
- STEP 6:**        **Secondary Interview:**  
Applicants are interviewed by the Chief and Assistant Chief of Police.
- STEP 7:**        **Psychological Test:**  
Applicants who successfully complete the Background Investigation / Interview are required to take the psychological test. Results are reviewed by the Chief of Police and remaining applicants are scheduled for the final interview.
- STEP 8:**        **Final Interview:**  
The final interview shall be conducted by the Chief of Police and the Town Administrator. A conditional offer of employment may be made by the Chief of Police pending the applicant's successful completion of a drug test and physical examination. Any employment offer made at this point in the process may be rescinded if the applicant does not successfully pass the drug test or physical examination.
- STEP 9:**        **Drug Test and Physical Exam:**  
Upon successful completion of both the drug test and physical exam, the applicant may be hired at the discretion of the Chief of Police.

# TOWN OF LEXINGTON SUMMARY OF BENEFITS

Applicants Copy  
(Do Not Return)

## The Town of Lexington provides the following benefits to all permanent, full-time employees:

- ◆ **Direct Deposit** – Payroll is deposited directly into the bank account of up to three accounts.
- ◆ **Holidays** – The town observes 12 official holidays per calendar year.
- ◆ **Annual Leave** – Five days the first year, 10 days for years 2-5, 15 days for years 6-15, and 20 days for years 16 and over. Accrual of leave is bi-weekly.
- ◆ **Sick Leave** – Same as Annual Leave.
- ◆ **Retirement Plan** – The Town of Lexington is a member of the South Carolina Retirement System. A retirement plan is provided for each employee at the state mandated cost for the town and the employee. In addition, the employee may choose to participate in the South Carolina Deferred Compensation program (401K, 457 plans).
- ◆ **Insurance** – A comprehensive medical and dental plan is provided for the employee. Group term life insurance in the amount of \$3,000 is included. Dependent Life/Spouse, Dependent Life/Child(ren), Long-Term Care, Supplemental Long Term Disability, and Optional Life are also available.
- ◆ **Money Plus** – A full Section 125 Flex Spending Plan is offered. This includes Premium Pass-Through, Medical Reimbursement and Dependent Care Reimbursement.
- ◆ **Credit Union Membership** – Available at **State Credit Union, Safe Credit Union & Ft. Jackson Federal Credit Union**. Services offered include free checking, savings, loans, etc. plus a full-service travel agency. Members can also purchase discount tickets to S.C. State Museum, Riverbanks Zoo, Biltmore Estate, Disney World, and the S.C. State Fair.
- ◆ **Fitness Center** – The town will pay for the employee's membership to a local fitness center.
- ◆ **Wellness and Safety** – The Town provides flu shots and annual health screenings for employees, as well as programs to promote health, wellness and safety.
- ◆ **Business Discounts** – Employees can receive discounts for contracted cell phones and computers through the Department of Information and Technology.
- ◆ **Compensation Policy** – (Merit increase) Performance appraisals are conducted when six months probation has ended. You must score at least 3.0 on the rating scale to receive an increase. This system is designed to put salaries at the mid-point after three-years of employment. Appraisals are then conducted annually on the anniversary of the date of hire. Annual bonuses.
- ◆ **Employee Appreciation** – Recognition for service after 5, 10, 15, 20 & 25 years.

\* If a position is offered, a pre-employment physical and drug screening is required.



# LEXINGTON POLICE DEPARTMENT

## Sworn Officer Employment Application

Revised 10/2009



**NOTE:** All statements are subject to verification and incorrect statements or omissions may bar or remove you from employment. Truthful statements to any item requested will not automatically remove you from employment. Data is used for periodic reporting and will be kept in a **CONFIDENTIAL FILE**.

**Full-Time Officer**

Please check position applying for

**Reserve Officer**

### BIOGRAPHICAL INFORMATION

**1. NAME:** \_\_\_\_\_  
Last First Middle Maiden Nickname

a) Has your name been legally changed or have you ever used another name? \_\_\_\_ Yes \_\_\_\_ No

b) If yes, list all names used: \_\_\_\_\_

### 2. CURRENT ADDRESS

Number Street

City State Zip

Length of time at this address: \_\_\_\_\_

Local Law Enforcement Agency: \_\_\_\_\_

### 3. CURRENT CONTACT INFORMATION

Home Telephone

Cell

Work/Office/Other

E-Mail

Check if you would prefer to be notified via e-mail  
ALONG WITH any telephone calls made.

**4. DATE OF BIRTH:** \_\_\_\_ / \_\_\_\_ / \_\_\_\_

**5. SOCIAL SECURITY NUMBER:**  
\_\_\_\_ - \_\_\_\_ - \_\_\_\_

**6. PLACE OF BIRTH:** \_\_\_\_\_  
Medical Facility City State

a) Has your date of birth ever been changed on a legal document?  Yes  No

b) If yes, explain: \_\_\_\_\_

### 7. ONLINE IDENTITIES:

a) Have you ever maintained any online social networking site (Myspace, Facebook, etc.)?  Yes  No

If yes, please list the service, web address and/or user ID for such: \_\_\_\_\_

**8. List complete name of any person(s) you are currently residing with (excluding immediate family members):**

Last First Middle Maiden Nickname

Last First Middle Maiden Nickname



---

## 9. PREVIOUS RESIDENCES

- a) List previous addresses for the last 10 years, beginning with the most recent. Include local law enforcement agency that has jurisdiction at the address and the time period which you resided there.

---

| Number | Street | City | State | Zip | Dates | Police Agency |
|--------|--------|------|-------|-----|-------|---------------|
|--------|--------|------|-------|-----|-------|---------------|

---

| Number | Street | City | State | Zip | Dates | Police Agency |
|--------|--------|------|-------|-----|-------|---------------|
|--------|--------|------|-------|-----|-------|---------------|

---

| Number | Street | City | State | Zip | Dates | Police Agency |
|--------|--------|------|-------|-----|-------|---------------|
|--------|--------|------|-------|-----|-------|---------------|

- b) List any individuals you have resided with during the last ten years (excluding family members):

---

| Last | First | Middle | Present Address | Phone Number |
|------|-------|--------|-----------------|--------------|
|------|-------|--------|-----------------|--------------|

---

| Last | First | Middle | Present Address | Phone Number |
|------|-------|--------|-----------------|--------------|
|------|-------|--------|-----------------|--------------|

---

| Last | First | Middle | Present Address | Phone Number |
|------|-------|--------|-----------------|--------------|
|------|-------|--------|-----------------|--------------|

---

## 10. FAMILY INFORMATION

- a) Please list the following information:

**Father:**

---

| Last | First | Middle | Present Address | Phone Number |
|------|-------|--------|-----------------|--------------|
|------|-------|--------|-----------------|--------------|

**Mother:**

---

| Last | First | Middle | Present Address | Phone Number |
|------|-------|--------|-----------------|--------------|
|------|-------|--------|-----------------|--------------|

**Brothers/Sisters:**

---

| Last | First | Middle | Present Address | Phone Number |
|------|-------|--------|-----------------|--------------|
|------|-------|--------|-----------------|--------------|

---

| Last | First | Middle | Present Address | Phone Number |
|------|-------|--------|-----------------|--------------|
|------|-------|--------|-----------------|--------------|

**Step-Father:**

---

| Last | First | Middle | Present Address | Phone Number |
|------|-------|--------|-----------------|--------------|
|------|-------|--------|-----------------|--------------|

**Step-Mother:**

---

| Last | First | Middle | Present Address | Phone Number |
|------|-------|--------|-----------------|--------------|
|------|-------|--------|-----------------|--------------|



b) Please indicate all schools that you have attended beginning with high school.

| School | City, State | Dates | Major | Type of Degree<br>(or "None") |
|--------|-------------|-------|-------|-------------------------------|
|        |             |       |       |                               |
|        |             |       |       |                               |
|        |             |       |       |                               |
|        |             |       |       |                               |
|        |             |       |       |                               |
|        |             |       |       |                               |

c) List any training, skills and/or experience that you feel would be particularly useful in the position for which you are applying: \_\_\_\_\_  
 \_\_\_\_\_  
 \_\_\_\_\_

d) Have you ever been suspended or expelled from any high school or post secondary school (any formal educational institution beyond the high school level)?  Yes  No

If yes, please explain to include school, date and circumstances:  
 \_\_\_\_\_  
 \_\_\_\_\_

---

#### 14. MILITARY SERVICE

a) Are you registered with the selective Service?  Yes  No

If no and a male, please explain: \_\_\_\_\_

b) Have you ever served in the armed forces?  Yes  No

If yes, please supply the following information (c) through (j):

c) Branch of Service: \_\_\_\_\_

d) If presently a member of the National Guard or any military reserve, give unit and location: \_\_\_\_\_  
 \_\_\_\_\_

e) Dates of Service: \_\_\_\_\_ to \_\_\_\_\_

f) Total Years: \_\_\_\_\_ Highest Rank: \_\_\_\_\_

g) Type of Discharge: \_\_\_\_\_ Date and Location: \_\_\_\_\_

h) List all medals and decorations awarded you during your military service: \_\_\_\_\_  
 \_\_\_\_\_

i) Have you ever been the subject of any judicial or non-judicial disciplinary action while in the military?  Yes  No

If yes, please give details to include branch of service, when, where, and circumstances: \_\_\_\_\_  
 \_\_\_\_\_

j) Have you ever been court-martialed while a member of the armed forces?  Yes  No

If yes, explain: \_\_\_\_\_  
 \_\_\_\_\_

## 15. MEDICAL INFORMATION

- a) Have you ever used illegal drugs?  Yes  No

If yes, state substance, date of use and approximate number of times of used: \_\_\_\_\_

- b) Do you habitually use alcoholic beverages to excess?  Yes  No

- c) Have you ever been treated for drug or alcohol addiction?  Yes  No

If yes, state substance, dates and location of treatments: \_\_\_\_\_

- e) Are you presently in a physical fitness program?  Yes  No

List type: \_\_\_\_\_

## 16. FINANCIAL INFORMATION

a)

| Monthly Income              |           |
|-----------------------------|-----------|
| Salary:                     | \$        |
| Spouses Salary:             | \$        |
| Other Income - Describe     | \$        |
|                             | \$        |
|                             | \$        |
|                             | \$        |
| <b>Total Monthly Income</b> | <b>\$</b> |

- b) How many persons do you support, including yourself? \_\_\_\_\_

- c) Have you ever been sued?  Yes  No

If yes, give details to include date, circumstances and disposition:

\_\_\_\_\_

\_\_\_\_\_

- d) List your total amount of debts at present. Include charge accounts, contracts, and any financial liabilities.

| Name of Debt Holder | City | State | Telephone | Total Debt | Monthly Payment |
|---------------------|------|-------|-----------|------------|-----------------|
|                     |      |       |           | \$         | \$              |
|                     |      |       |           | \$         | \$              |
|                     |      |       |           | \$         | \$              |
|                     |      |       |           | \$         | \$              |
|                     |      |       |           | \$         | \$              |
| <b>Total</b>        |      |       |           |            | <b>\$</b>       |

- e) Have you ever filed for or declared bankruptcy?  Yes  No  
 If yes, please give details to include when, where, court and circumstances: \_\_\_\_\_  
 \_\_\_\_\_
- f) Have you ever had any of your bills turned over to a collection agency?  Yes  No  
 If yes, please give details to include when, firms involved, and circumstances: \_\_\_\_\_  
 \_\_\_\_\_
- g) Have you ever had purchased goods repossessed?  Yes  No  
 If yes, please give details to include when, firms involved and circumstances: \_\_\_\_\_  
 \_\_\_\_\_
- h) Have your wages ever been garnished?  Yes  No  
 If yes, please give details to include when, where, and why: \_\_\_\_\_  
 \_\_\_\_\_
- i) Have you ever been delinquent on income or other tax payment?  Yes  No  
 If yes, please give details to include when, where, and why: \_\_\_\_\_  
 \_\_\_\_\_

## 17. PERSONAL QUESTIONNAIRE

- a) Do you object to wearing a uniform?  Yes  No
- b) Do you object to working overtime?  Yes  No
- c) Do you object to being away from home for long periods of time?  Yes  No
- d) Do you object to working regular shifts?  Yes  No
- e) Do you object to working rotating shifts?  Yes  No
- f) Do you object to working nights and/or weekends?  Yes  No
- g) Do you object to working in adverse environmental conditions?  Yes  No
- h) Can you operate a motor vehicle?  Yes  No
- i) Do you fluently speak any foreign language?  Yes  No  
 If yes, list language(s): \_\_\_\_\_
- j) Do you hold any professional licenses?  Yes  No  
 If yes, list: \_\_\_\_\_

## 18. CRIMINAL HISTORY

- a) Have you ever been arrested by law enforcement?  Yes  No  
 If yes, give details:

| *Offense Charged | Police Agency | State | Date | Disposition |
|------------------|---------------|-------|------|-------------|
|                  |               |       |      |             |
|                  |               |       |      |             |
|                  |               |       |      |             |

\*If a charge was reduced, the original charge should be listed and the reduced charge listed under "disposition"

- b) Have you ever been convicted of a felony?  Yes  No  
 If yes, give details: \_\_\_\_\_  
 \_\_\_\_\_
- c) Have you ever been investigated, arrested, prosecuted or convicted for Domestic Violence?  Yes  No  
 If yes, please explain: \_\_\_\_\_  
 \_\_\_\_\_
- d) Have you ever been the subject of a court order or placed on probation?  Yes  No  
 If yes, please explain: \_\_\_\_\_  
 \_\_\_\_\_
- e) Have you ever been prohibited by a court from possessing a firearm?  Yes  No  
 If yes, please explain: \_\_\_\_\_  
 \_\_\_\_\_
- f) Were you ever required to appear before a juvenile court for an act which would have been a crime if committed by an adult?  Yes  No  
 If yes, give details to include when, where, and why: \_\_\_\_\_  
 \_\_\_\_\_
- g) Have you ever been reported to a law enforcement agency as a missing person or runaway?  Yes  No  
 If yes, please give details to include; date, law enforcement agency, and circumstances: \_\_\_\_\_  
 \_\_\_\_\_
- h) Did you ever lie about anything really important or to stay out of trouble?  Yes  No  
 If yes, explain: \_\_\_\_\_  
 \_\_\_\_\_
- i) Has anyone ever taken out a warrant on you?  Yes  No  
 If yes, please give details to include; date, law enforcement agency, and circumstances: \_\_\_\_\_  
 \_\_\_\_\_
- j) Have you ever been contacted and/or questioned by law enforcement as a possible suspect for any kind of criminal investigation?  Yes  No  
 If yes, please give details to include; date, law enforcement agency, and circumstances: \_\_\_\_\_  
 \_\_\_\_\_
- k) Have you ever stolen anything or altered price tags in a store?  Yes  No  
 If yes, explain to include date, from who, and circumstances: \_\_\_\_\_  
 \_\_\_\_\_
- l) Were you ever in court as a defendant?  Yes  No  
 If yes, please explain to include dates: \_\_\_\_\_  
 \_\_\_\_\_

m) Have you ever lied under oath in court or on any official document?  Yes  No

If yes, please explain to include dates and circumstance(s): \_\_\_\_\_  
\_\_\_\_\_  
\_\_\_\_\_

n) Please check any of the following **undetected** crimes you may have ever committed or participated in and explain.

- |   |  |  |
|---|--|--|
| <input type="checkbox"/> ARSON                          | <input type="checkbox"/> FISH AND GAME VIOLATION | <input type="checkbox"/> CRIMINAL DAMAGE TO PROPERTY |
| <input type="checkbox"/> BURGLARY                       | <input type="checkbox"/> SHOPLIFTING             | <input type="checkbox"/> ILLEGAL USE OF CREDIT CARDS |
| <input type="checkbox"/> ILLEGAL DRUGS                  | <input type="checkbox"/> CHILD MOLESTATION       | <input type="checkbox"/> INCEST                      |
| <input type="checkbox"/> ARMED ROBBERY                  | <input type="checkbox"/> THEFT                   | <input type="checkbox"/> RECEIVING STOLEN PROPERTY   |
| <input type="checkbox"/> ASSAULT                        | <input type="checkbox"/> VANDALISM               | <input type="checkbox"/> PUBLIC DRUNKENESS           |
| <input type="checkbox"/> GAMBLING                       | <input type="checkbox"/> ILLEGAL WIRETAP         | <input type="checkbox"/> COMPUTER "HACKING"          |
| <input type="checkbox"/> MURDER                         | <input type="checkbox"/> KIDNAPPING              | <input type="checkbox"/> RAPE                        |
| <input type="checkbox"/> DOMESTIC VIOLENCE              | <input type="checkbox"/> TRESPASSING             | <input type="checkbox"/> FORGERY                     |
| <input type="checkbox"/> PERJURY                        | <input type="checkbox"/> BRIBERY                 | <input type="checkbox"/> CONCEALED WEAPON            |
| <input type="checkbox"/> ILLEGAL POSSESSION OF FIREARMS |  |  |

\_\_\_\_\_  
\_\_\_\_\_  
\_\_\_\_\_

o) If none of the above, list the most serious **undetected** crime you were ever involved in and explain: \_\_\_\_\_

\_\_\_\_\_  
\_\_\_\_\_  
\_\_\_\_\_

**19. DRIVING HISTORY**

a) Do you possess a current valid driver's license?  Yes  No  
Driver's License Number: \_\_\_\_\_ State: \_\_\_\_\_

b) Have you ever possessed a driver's license issued by any other state?  Yes  No  
If yes, give state and number: \_\_\_\_\_

c) Has your license ever been suspended or revoked?  Yes  No  
If yes, give details to include reason, state, and date:

| Reason | State | Date | Restored (yes/no) | Date |
|--------|-------|------|-------------------|------|
|--------|-------|------|-------------------|------|

d) Are your driving privileges restricted?  Yes  No  
List restrictions: \_\_\_\_\_

e) List all States you have ever resided in: \_\_\_\_\_  
\_\_\_\_\_

- f) Have you ever had any traffic violations?  Yes  No  
 If yes, please list:

| *Traffic Violation | Police Agency | Date | Disposition and Sentence |
|--------------------|---------------|------|--------------------------|
|                    |               |      |                          |
|                    |               |      |                          |
|                    |               |      |                          |
|                    |               |      |                          |
|                    |               |      |                          |

\*If a charge was reduced, the original charge should be listed and the reduced charge listed under “disposition”

- g) List the current liability insurance that you have on your motor vehicles.

| Company | Agent | Phone Number | Policy Number | Expiration Date |
|---------|-------|--------------|---------------|-----------------|
|         |       |              |               |                 |
|         |       |              |               |                 |

- h) Have you ever had a lapse in automobile liability insurance?  Yes  No

## 20. EMPLOYMENT HISTORY

- a) Have you ever been or are you now engaged in a private business?  Yes  No

If yes, list your capacity, name of business and dates: \_\_\_\_\_

- b) Have you ever been discharged or asked to resign from a job?  Yes  No

If yes, give business name(s), date(s) and circumstances: \_\_\_\_\_

- c) Have you ever applied for employment at any other law enforcement agency in South Carolina?  Yes  No

If yes, please list agencies, dates, and how for in their process you went:

| Agency | Date(s) | Length in Process |
|--------|---------|-------------------|
|        |         |                   |
|        |         |                   |
|        |         |                   |
|        |         |                   |
|        |         |                   |



d) Please list all jobs (including part-time, temporary, and volunteer) for the previous ten (10) years beginning with the current or most recent. **All** time should be accounted for chronologically. If you were a student or unemployed, the dates should be filled in and so noted beside “company name”.

|  |                           |
|--|---------------------------|
| <b>Company Name:</b>   | <b>Supervisor:</b>        |
| <b>Employment Dates:</b> From / / To / /   | <b>Telephone #:</b> ( ) - |
| <b>Address:</b>  |                           |
| <b>Job Title:</b>  | <b>Ending Salary:</b> \$  |
| <b>Job Duties:</b>   |                           |
| <b>Reason for Leaving:</b>   |                           |
| <b>May we contact this employer?</b> <input type="checkbox"/> Yes <input type="checkbox"/> No <b>If "no", explain:</b> |                           |

|  |                           |
|--|---------------------------|
| <b>Company Name:</b>   | <b>Supervisor:</b>        |
| <b>Employment Dates:</b> From / / To / /   | <b>Telephone #:</b> ( ) - |
| <b>Address:</b>  |                           |
| <b>Job Title:</b>  | <b>Ending Salary:</b> \$  |
| <b>Job Duties:</b>   |                           |
| <b>Reason for Leaving:</b>   |                           |
| <b>May we contact this employer?</b> <input type="checkbox"/> Yes <input type="checkbox"/> No <b>If "no", explain:</b> |                           |

|  |                           |
|--|---------------------------|
| <b>Company Name:</b>   | <b>Supervisor:</b>        |
| <b>Employment Dates:</b> From / / To / /   | <b>Telephone #:</b> ( ) - |
| <b>Address:</b>  |                           |
| <b>Job Title:</b>  | <b>Ending Salary:</b> \$  |
| <b>Job Duties:</b>   |                           |
| <b>Reason for Leaving:</b>   |                           |
| <b>May we contact this employer?</b> <input type="checkbox"/> Yes <input type="checkbox"/> No <b>If "no", explain:</b> |                           |

|  |                           |
|--|---------------------------|
| <b>Company Name:</b>   | <b>Supervisor:</b>        |
| <b>Employment Dates:</b> From / / To / /   | <b>Telephone #:</b> ( ) - |
| <b>Address:</b>  |                           |
| <b>Job Title:</b>  | <b>Ending Salary:</b> \$  |
| <b>Job Duties:</b>   |                           |
| <b>Reason for Leaving:</b>   |                           |
| <b>May we contact this employer?</b> <input type="checkbox"/> Yes <input type="checkbox"/> No <b>If "no", explain:</b> |                           |

|  |                           |
|--|---------------------------|
| <b>Company Name:</b>   | <b>Supervisor:</b>        |
| <b>Employment Dates:</b> From / / To / /   | <b>Telephone #:</b> ( ) - |
| <b>Address:</b>  |                           |
| <b>Job Title:</b>  | <b>Ending Salary:</b> \$  |
| <b>Job Duties:</b>   |                           |
| <b>Reason for Leaving:</b>   |                           |
| <b>May we contact this employer?</b> <input type="checkbox"/> Yes <input type="checkbox"/> No <b>If "no", explain:</b> |                           |

|  |                           |
|--|---------------------------|
| <b>Company Name:</b>   | <b>Supervisor:</b>        |
| <b>Employment Dates:</b> From / / To / /   | <b>Telephone #:</b> ( ) - |
| <b>Address:</b>  |                           |
| <b>Job Title:</b>  | <b>Ending Salary:</b> \$  |
| <b>Job Duties:</b>   |                           |
| <b>Reason for Leaving:</b>   |                           |
| <b>May we contact this employer?</b> <input type="checkbox"/> Yes <input type="checkbox"/> No <b>If "no", explain:</b> |                           |





**LEXINGTON POLICE DEPARTMENT**  
Sworn Officer Employment Application Affidavit

**STATE OF SOUTH CAROLINA**  
**COUNTY OF LEXINGTON**

I hereby certify that I, \_\_\_\_\_, am not attempting to hide or conceal any information concerning my background and that the information provided is correct and complete to the best of my knowledge and understand that any omissions, incomplete or false statements and/or information furnished by me may subject me to disqualification or termination at any time after employment.

I have read the above and understand that applications not completed in their entirety shall not be considered.

I also understand and agree that if I am hired, I will be employed “at will” which means that I may terminate my employment at any time, with or without cause, and that the Town of Lexington will have the same right.

This the \_\_\_\_\_ day of \_\_\_\_\_, 20 \_\_\_\_\_

\_\_\_\_\_  
Full Signature of Applicant

Subscribed and Sworn to before me this \_\_\_\_\_ day of \_\_\_\_\_, A.D. 20 \_\_\_\_\_.

My Commission Expires: \_\_\_\_\_

Notary Public: \_\_\_\_\_

**LEXINGTON POLICE DEPARTMENT**  
**SUPPLEMENT TO EMPLOYMENT APPLICATION**  
**APPLICANT ELIGIBILITY ATTESTATION**

I understand that the US Government requires the company to verify my eligibility for US employment and my identity. I understand that the company must decline to hire me if I fail to present adequate proof of my eligibility and identity.

As evidence of eligibility and identity, the government requires applicants to submit originals of one document from Group "A" OR one document for both Group "B" and Group "C".

Please check the evidence you will submit:

| Group A  | Group B   | Group C.   |
|--|---|--|
| <input type="checkbox"/> US Passport   | <input type="checkbox"/> Social Security Card<br>(absent no work endorsement)   | <input type="checkbox"/> State Drivers License<br>(with photograph)              |
| <input type="checkbox"/> Certificate of US Citizenship   | <input type="checkbox"/> US Birth Certificate<br>(establishing US Nationality at birth)   | <input type="checkbox"/> Other form of State ID<br>(with photograph)             |
| <input type="checkbox"/> Certificate of Naturalization   | <input type="checkbox"/> Other Document<br>(approved by Attorney General<br>authorizing employment by the applicant<br>in the US) | <input type="checkbox"/> Other Photo ID<br>(approved by the Attorney<br>General) |
| <input type="checkbox"/> Unexpired foreign passport<br>(with un-expired work authorization<br>endorsement of Attorney General) |   |  |
| <input type="checkbox"/> I-551 Alien Registration Receipt<br>Card (with photograph)  |   |  |

I declare and affirm under penalty of perjury that I am (check the appropriate box):

- A Citizen or National of the United States.
- An alien lawfully admitted for U.S. permanent residence.
- An alien authorized under the US Immigration and Nationality Act to be hired in the position for which I have applied.

\_\_\_\_\_  
 Printed Name

\_\_\_\_\_  
 Date

\_\_\_\_\_  
 Signature



**Police Department**

Terrence Green, Chief of Police  
111 Maiden Lane • Lexington, SC 29072  
803-359-6260 (Phone) • 803-951-4643 (Fax)

“Building Partnerships with the Community We Serve”

**Lexington Police Department  
Employment Application  
Authorization for Release of Information**

**To Any:**

Doctor, Hospital, Medical Association, U.S. Armed Forces,  
U.S. Selective Service System, Maritime Service, Veterans Administration, or

Academic Dean, Registrar, Principal, Guidance Counselor, other authorized person at a school (college, business,  
trade or high school), or

Past or present Employer, or

Credit Bureau or Retail Merchants Association, Bank, Financial Institution or any other Credit Extending  
Organization, or

Municipal, County, State, or Federal Governmental Agency.

I, \_\_\_\_\_, have applied for employment with the Lexington  
Police Department. I am aware that my entire background is to be investigated and hereby authorize and request the  
release of any and all information you have concerning me, excluding bank or savings and loan association balances,  
to the Lexington Police Department or its agents. I hereby designate the Lexington Police Department as my  
authorized representative for the purpose of obtaining such information.

I hereby release anyone addressed above, who gives information about me in the course of an investigation covered  
by this authorization, from any and all liability for damages of whatever kind to me, my family, heirs or associates  
as a result of giving such information, except that I do not release anyone who gives information that he knows is  
false, deliberately intending to harm me or one of my family, heirs or associates.

Printed Name: \_\_\_\_\_

Signature: \_\_\_\_\_

Date \_\_\_\_\_

**Subscribed and Sworn to before me this \_\_\_\_\_ day of \_\_\_\_\_, A.D. 20\_\_\_\_\_.**

**My Commission Expires \_\_\_\_\_.**

**Notary Public:** \_\_\_\_\_



An Internationally and State Accredited Agency

